



55 Coonara Avenue West Pennant Hills

Planning Proposal Revision 4

Traffic Assessment

July 2017

prepared for

Mirvac

prepared by

ARC Traffic + Transport

# Introduction

Mirvac proposes the rezoning of 55 Coonara Avenue, West Pennant Hills (the Site), to provide for a residential development project. The Planning Proposal (the Proposal) supporting the rezoning provides for: -

- A total of 200 low density residential dwellings (detached, semi-detached, attached houses and townhouses)
- A total of 400 apartment dwellings, indicatively including: -
  - 20 studio apartments
  - 100 one-bedroom apartments
  - 220 two-bedroom apartments
  - 60 three-bedroom apartments
- A total of approximately 940 parking spaces (including 80 visitor spaces for the apartment component of the Proposal), or some 670 spaces less than currently provided on-site.

ARC Traffic + Transport (ARC) has been commissioned to provide an assessment of the access, traffic and parking characteristics of the Proposal, and the potential impacts on the local road network arising from the Proposal. In preparing this assessment, ARC has: -

- Discussed the Proposal with Mirvac and GLN Planning;
- Discussed the Proposal and the operation of the local road network with representatives of Hills Shire Council (Council), NSW Department of Planning & Environment (DP&E); Transport for NSW (TNSW); and the Roads & Maritime Authority (RMS);
- Commissioned and reviewed peak period traffic surveys of the Site and key local intersections;
- Examined 'existing' Site trip generation and distribution characteristics – with specific focus on the potential 'capacity' operations of the Site based on its current zoning and on-site parking provisions, and the operation of the local road network subject to that potential trip generation;
- Determined the trip generation of the Site further to the Proposal, and the operation of the local road network further to the introduction of those trips; and
- Referenced Council's [The Hills DCP 2012 \(Hills DCP\)](#) and [The Hills LEP 2012 \(Hills LEP\)](#), as well as available planning and transport assessments relating to the North West Rail Link (NWRL); the (draft) Hills Corridor Strategy ([Corridor Strategy](#)); and the Cherrybrook (Railway Station) Precinct in which the Site lies.

From the outset, it is noted that this assessment revises a number of previous assessments prepared by ARC in regard to the Site, including: -

- A January 2016 assessment considering the development of 1,269 dwellings on the Site, which accompanied a Planning Proposal submitted to Council in March 2016. ([January 2016 TA](#))

- A July 2016 assessment considering the development of 1,119 dwellings on the Site, which accompanied a Planning Proposal submitted to Council in August 2016. ([July 2016 TA](#))
- An October 2016 assessment considering the development of 800 dwellings on the Site, which accompanied a Planning Proposal submitted to Council in October 2016. ([October 2016 TA](#))

Per the above, this revised Proposal represents a reduction of some 669 dwellings from the initial March 2016 Planning Proposal; a reduction of some 519 dwellings from the August 2016 Planning Proposal; and a reduction of some 200 dwellings from the most recent October 2016 Planning Proposal.

It is our understanding that this current Proposal was revised by Mirvac in consultation with Council, and this assessment of the 600 dwelling Proposal specifically considers feedback provided by Council officers in regard to all past assessments. ARC would specifically acknowledge our detailed discussions with Mr Andrew King (Manager of Infrastructure Planning), Mr Stewart Seale (Manager of Forward Planning) and Mr Michael Edgar (formerly Group Manager of Strategic Planning) in regard to key traffic and transport issues. The assessment methodology provided herein is identical to that previously discussed and agreed with Council officers in regard to the past assessments outlined above.

Further to the preparation of the [October 2016 TA](#), Mirvac also commissioned a [Peer Review](#) of the methodology and conclusions provided in the [October 2016 TA](#), as well as a broader review of the October 2016 Planning Proposal with a specific focus on the 'walkability' of the Site, and specifically pedestrian access between the Site and the future Cherrybrook Station. This [Peer Review](#) was completed by ASON Group, and was previously provided to Council by Mirvac.

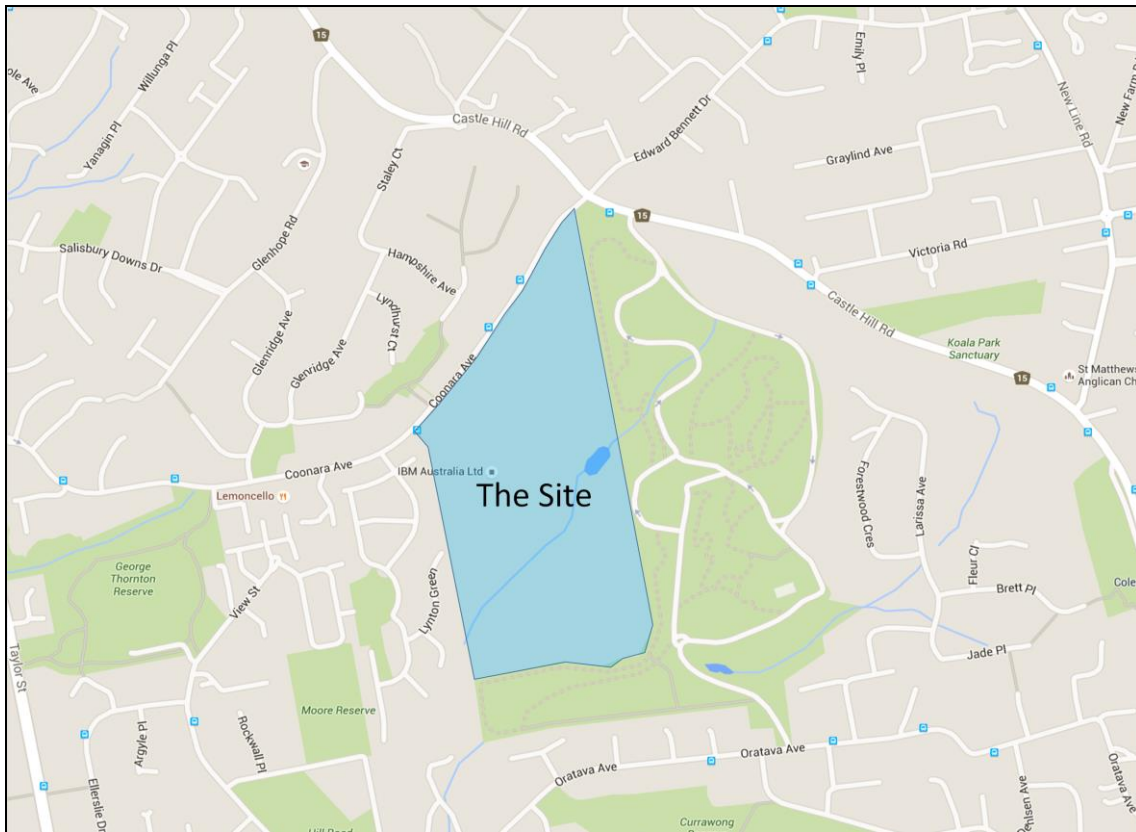
Finally, it is essential to state that the Proposal would entirely replace commercial operations at the Site, operations which it is acknowledged have been significantly reduced over recent years but could return to capacity operations 'tomorrow' based on existing planning/zoning provisions and Site infrastructure/GFA. As such, in assessing the Proposal it is entirely appropriate to examine the peak potential impacts of those capacity commercial operations – based on some 34,000m<sup>2</sup> of commercial office space and moreover some 1,613 parking spaces across the Site – for comparison with the Proposal.

# 1 The Existing Site

## 1.1 Location

The Site is located at 55 Coonara Avenue, West Pennant Hills, and is shown in its local context in **Figure 1.1** below.

**Figure 1.1** Location



Source: GoogleMaps

## 1.2 Usage

The Site was purpose built for IBM in the 1980's, and comprises 34,000m<sup>2</sup> GFA, which includes a data centre and disaster recovery centre. A total of some 1,613 parking spaces are provided on-site, or approximately 1 space per 20m<sup>2</sup> GFA.

More recently, IBM have downsized at the Site, leasing only 16,500m<sup>2</sup> GFA of office area. Lend Lease Bouygues currently lease some 5,000m<sup>2</sup> GFA, and approximately 4,600m<sup>2</sup> of the original total GFA has been converted to common area. Some 7,500m<sup>2</sup> GFA remains vacant at this time.

It is noted also that staff levels (a key driver of traffic generation) at the Site have also fallen significantly over time. At peak occupancy in the 1980's, IBM employed approximately 3,500 staff on-site; by 2009, that figure had slightly reduced to 3,000 staff, but at this time (2015) it is estimated that some 1,200 people are employed across the Site (all tenants). Employment figures provided in the Corridor Strategy indicate that there were 2,237 jobs in the Cherrybrook Precinct in 2011, almost all of which are focused at the Site.

## 1.3 Access

### 1.3.1 Site Access

The Site has two vehicle access points to Coonara Avenue, located approximately 330m and 540m south of the intersection with Castle Hill Road. Both access points provide for two-way movements, and left and right turns to and from the Site are permitted at each. ARC has termed these access points Access North and Access South for ease of reference in later sections. These access points connect to an internal road network providing access to car parks and service. It is noted that the internal road network also provides what is essentially a perimeter road between the built environment and surrounding bushland.

While barrier gates are provided at both access points, our observations suggest that access to/from the Site is currently unrestricted.

### 1.3.2 Sub-Regional Access

Primary access to the sub-regional road network is provided via Coonara Avenue to the intersection of Castle Hill Road & Edward Bennet Drive. Castle Hill Road in turn links to the south-east (to Pennant Hills Road and the M2); and to the north-east (to Showground Road and Windsor Road). Edward Bennet Drive links north to Cherrybrook and then through to Dural.

Secondary access to the sub-regional network is provided via Coonara Avenue south to Taylor Street and then to Aitken Road to Pennant Hills Road south of Castle Hill Road; and via Oakes Road and Jenkins Road to Pennant Hills Road at Carlingford.

## 1.4 Local Road Network

The local road network is shown in **Figure 1.1** and further examined below.

## 1.4.1 Key Roads

Coonara Avenue is a wide local collector road providing two lanes for two-way traffic, and parking lanes on both sides which have been adapted (on the eastern side of Coonara Avenue) to provide short designated left turn lanes on the approaches to the Site access points. An additional short lane is also provided on the approach to Castle Hill Road. Coonara Avenue has a speed limit of 50km/h.

Castle Hill Road in the vicinity of the Site provides 4 lanes for two-way traffic, with significant additional approach infrastructure at the intersection of Coonara Avenue & Edward Bennet Drive. Castle Hill Road has a speed limit of 60km/h.

## 1.4.2 Intersection of Castle Hill Road & Coonara Avenue & Edward Bennet Drive

The key intersection in the local road network is the signalised intersection of Castle Hill Road & Coonara Avenue & Edward Bennet Drive.

Traffic surveys were conducted at the intersection in 2015 during the AM and PM peak periods. Analysis of intersection operations using the SIDRA model indicates that the intersection currently operates at an acceptable level of service 'C' in the AM peak period but at a level of service 'E' in the PM peak period, with capacity constraints on the Coonara Avenue approach specifically associated with the significant departure peak of the Site under existing commercial operations (see also **Section 2** below).

The Corridor Strategy indicates that the intersection will be upgraded to provide additional approach lanes in both Coonara Avenue and Edward Bennet Drive, and an extension of the right turn lane in Castle Hill Road to Coonara Avenue. It is noted that a signalised pedestrian crossing of the Coonara Avenue approach was recently installed.

At present, the intersection operates with split phasing of the Coonara Avenue and Edward Bennet Drive approaches. Further to our discussions with Council, the RMS and TNSW, it is anticipated that additional approach lanes (further to an upgrade by others) may allow for future diamond turn phasing.

Notwithstanding the above, while our discussions with Mr King have confirmed that the intersection will be upgraded (by others), the design of the upgrade remains to be finalised pending investigations in regard to the broader Cherrybrook Precinct, and indeed of the broader NWRL Corridor. While the upgrades outlined above (based on available information) are certainly logical in the context of likely future growth (in accordance with the Corridor Strategy) it remains the case that the final design/phasing of the intersection has not been determined at this time.

Irrespective, and with reference to sections below, the Proposal is not contingent on any additional upgrades as the Proposal would result in similar or improved levels of service at the intersection when compared to potential capacity commercial operations at the Site.

### 1.4.3 Southern Roads

Further to our recent discussions with Mr King, it is also noted that some roads to the south of Coonara Avenue are currently experiencing queuing constraints (and general delays), particularly in the AM peak along sections of Taylor Street, Aitkens Road and Oakes Road.

Council is currently (July 2017) finalising proposals to provide bus priority lanes along this route, linking to a bus only bridge connecting Highs Road (in the vicinity of Daveney Way) with Castlewood Drive (and then Crane Road through to Castle Hill), and in turn providing direct and efficient bus services between Castle Hill and Parramatta. The expectation is that such bus services will encourage public transport trips along this sub-regional route, and in turn reduce private vehicle demands.

As discussed and agreed with Mr King, a detailed assessment of this southern route is outside the scope of a Planning Proposal assessment. Notwithstanding, with reference to sections below it is estimated that the Proposal would generate approximately 150 fewer trips to this route in the AM peak, and approximately 125 fewer trips to this route in the PM peak, than would be generated by capacity commercial operations at the Site.

### 1.4.4 Site Intersections

The two Site access intersection both operate as priority 'T' intersections; as discussed, both provide a designated left turn lane from Coonara Avenue to the Site. Analysis of intersection operations using the SIDRA model indicates that these intersections currently operate at a good level of service with minimal delays in both peak periods (see also traffic data in **Section 2** below).

## 1.5 Public Transport

### 1.5.1 Rail

The Site lies within 800m of the future Cherrybrook Railway Station, part of the North West Rail Link currently under construction. The NWRL will connect between Cudgegong Road and Epping, and thence to the broader Sydney rail network at Chatswood, with trains forecast to operate at a 4-minute headway through peak periods.

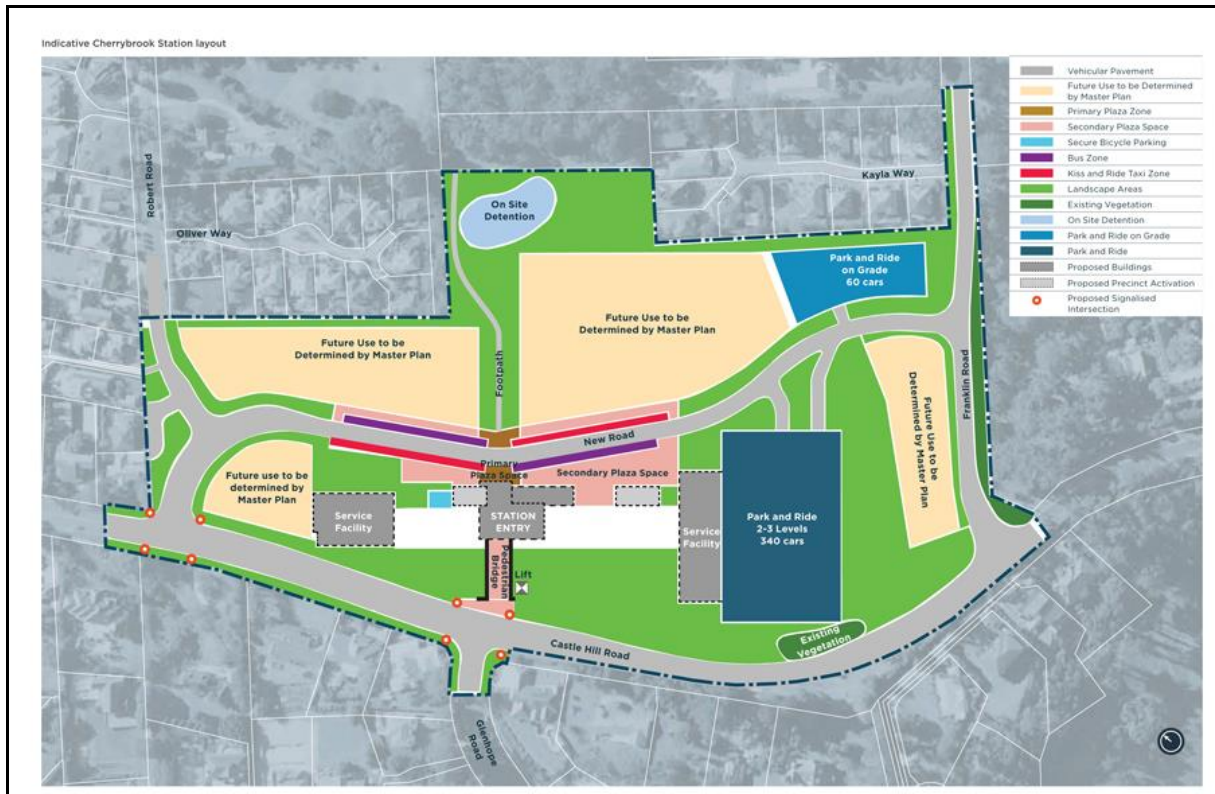
The NWRL is shown in **Figure 1.5.1.1**, while the future Cherrybrook Station is shown in **Figure 1.5.1.2**.

Figure 1.5.1.1 North West Rail Link



Source: Transport NSW

Figure 1.5.1.2 Cherrybrook Station Design



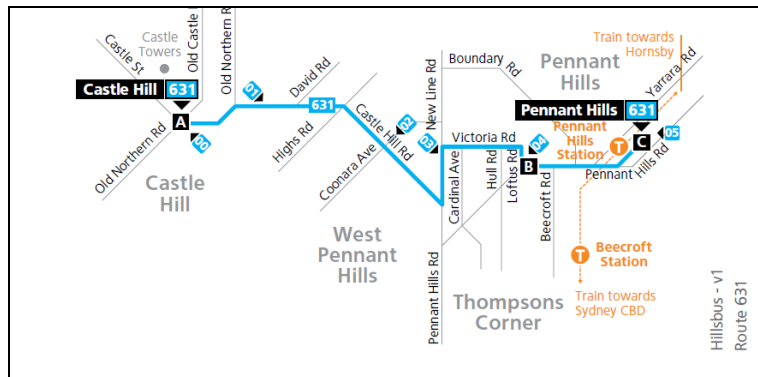
Source: Transport NSW

## 1.5.2 Bus Services

Bus services operate along Castle Hill Road to the north of the Site, and along Coonara Avenue directly adjacent to the Site. Existing routes provide access to key local destinations including Castle Hill and Pennant Hills (and specifically Pennant Hills Station) and sub-regional destinations (Macquarie Park, North Sydney and the CBD). Existing routes are shown in the figures below.

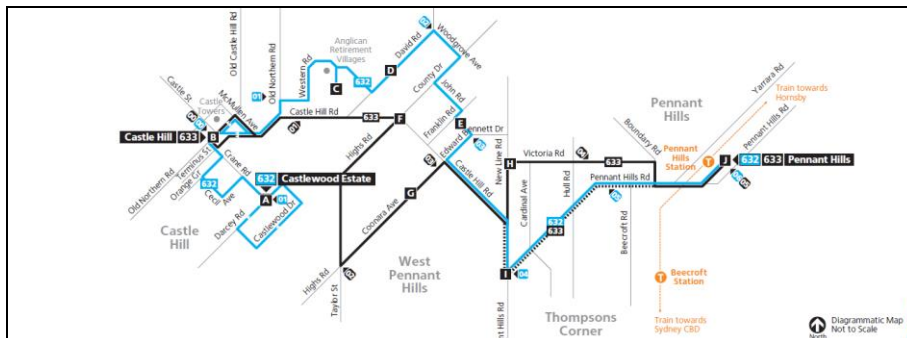


**Figure 1.5.2.1 Bus Route 631**



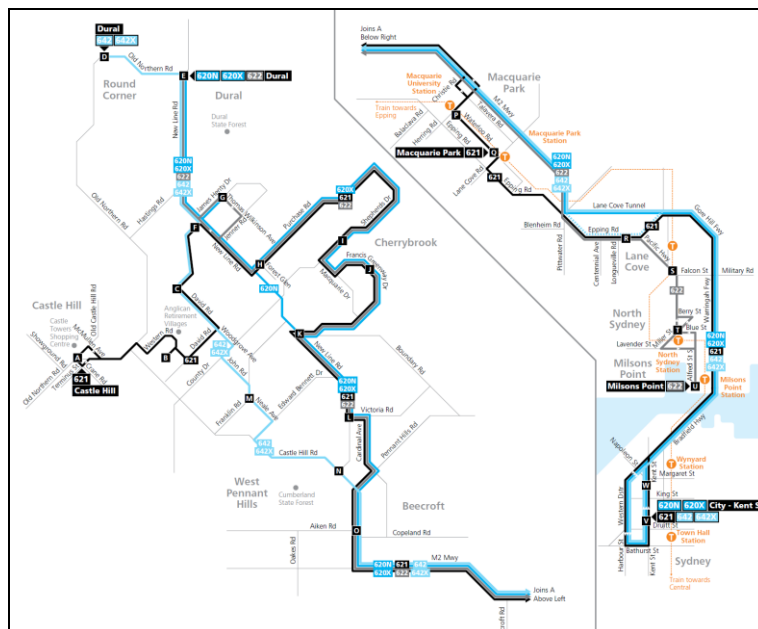
Source: Transport NSW

**Figure 1.5.2.2 Bus Routes 632/633**



Source: Transport NSW

**Figure 1.5.2.3 Bus Routes 642/642X**



Source: Transport NSW

The 642/642X services operate at a high frequency in the commuter peak periods, and currently has high patronage levels; however, a high percentage of these patrons are likely to switch to the NWRL once operational. Local services – and specifically the 633 service past the Site – generally operate at a 30-minute headway through the commuter periods; there is potential for these services to increase as feeder services (to Cherrybrook Station) once the NWRL is operational.

As also discussed in **Section 1.4.3**, Council is currently finalising proposals for new bus services and bus priority lanes between Castle Hill and Parramatta via Crane Road, Castlewood Drive and a new bus only bridge to Highs Road (and then south via Taylor Street, Aitkens Road and Oakes Road towards Parramatta). This will provide a significant new bus corridor through the local area, and the potential exists for local routes (via Coonara Avenue) as described above to also connect to this corridor (west to Castle Hill and/or south to Parramatta).

## 1.6 Pedestrian & Cycle

### 1.6.1 Infrastructure

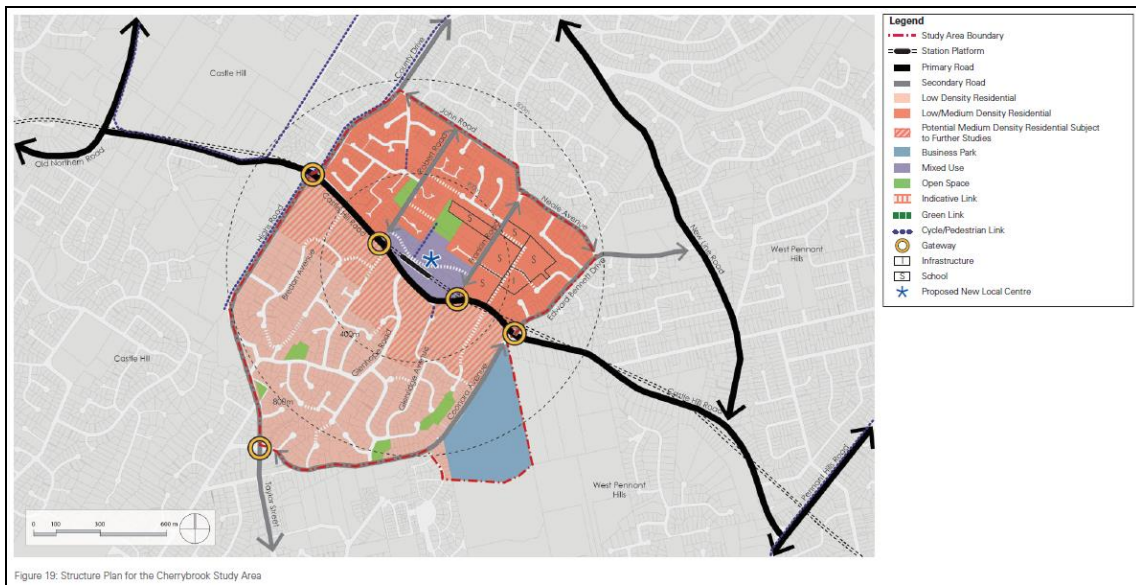
A pedestrian path is provided on the eastern side of Coonara Avenue south from Castle Hill Road to a pedestrian path into the Site itself located immediately north of Access North; this in turn provides access to the on-site pedestrian path network. No pedestrian path is provided along Coonara Avenue south of this divergence. A pedestrian path was also recently constructed along the western side of Coonara Avenue from Castle Hill Road south to Glenroe Avenue.

Castle Hill Road itself provides pedestrian paths on both sides of the road, which link to the east and west, and importantly connect through to the future Cherrybrook Station. On the southern side of Castle Hill Road, a relatively new and wide path (suitable as a shared path) is available which now connects to both the signalised crossing of the Coonara Avenue approach, and the pedestrian path along the western side of Coonara Avenue.

A pedestrian route to the future Cherrybrook Station is also available via Grosvenor Place Reserve opposite the Site, linking to Hampshire Avenue and Stanley Circuit (to Castle Hill Road); however, these minor roads do not provide dedicated pedestrian infrastructure. Pedestrian paths/trails are also available through the adjacent Cumberland Forest to Castle Hill Road.

Further to the above, the NWRL Cherrybrook Station Structure Plan (Cherrybrook Structure Plan) indicates the future provision of new links through the land opposite the Site to an internal road network within the (largely undeveloped) land south of Castle Hill Road and west of Coonara Avenue. With specific regard to the Site, the Cherrybrook Structure Plan indicates a new link directly opposite the Site connecting through to Hampshire Avenue and then north to Staley Court (which would then be provided with a pedestrian/cycle link to Castle Hill Road opposite Cherrybrook Station); and there is the potential to connect further west from this new link to Glenhope Road and direct to the main Cherrybrook Station entrance at Castle Hill Road.

**Figure 1.6.1** Cherrybrook Structure Plan



Source: TNSW/DP&E

These routes would additionally reduce walking distance/time between the Site and Cherrybrook Station.

An overview of the primary walk route via Coonara Avenue and Castle Hill Road is provided in **Figure 1.6.2** below.

**1.6.2 Walk Distances to Cherrybrook Station via Coonara Avenue and Castle Hill Road**



Source: Mirvac

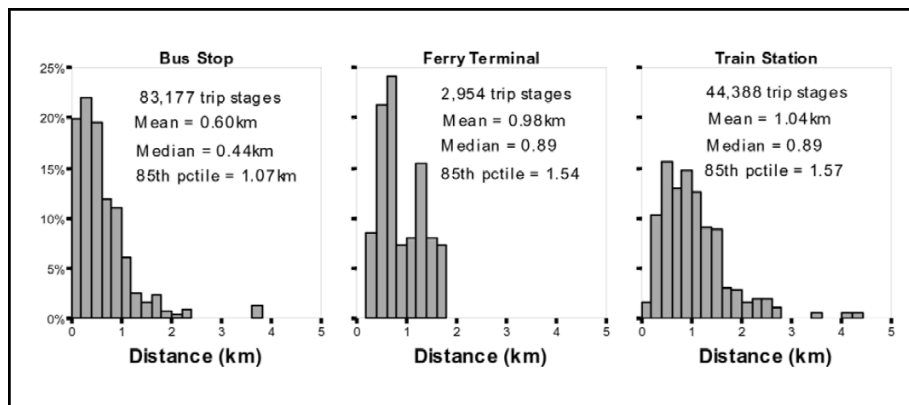
### 1.6.2 'Walkability'

As shown in the Cherrybrook Structure Plan (Figure 1.6.1 above) the Site lies within 800m of Cherrybrook Station, a distance which is often adopted as the 'standard' for walkability to rail stations. While it is acknowledged that walking distance between the central and southern parts of the Site and Cherrybrook Station would exceed 800m, there is a significant amount of data/research available showing that walk distance to good quality public transport – and particularly high frequency rail services – is not limited to an 800m catchment area.

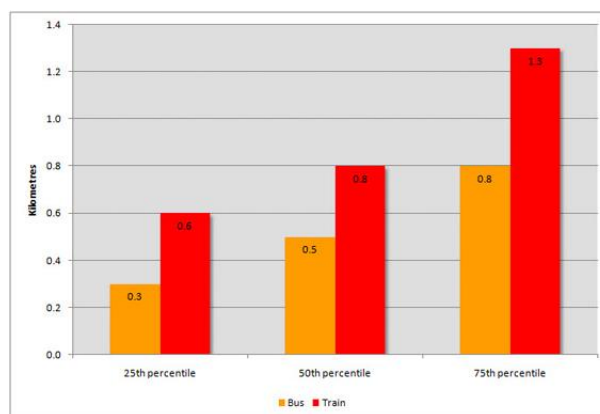
Indeed, it is illogical to suggest that walkability is acceptable for a dwelling 795m from a station but not 805m from a station; or that a gradient which may be uphill on a departure trip (but necessarily downhill on an arrival trip) would inherently reduce walkability. Further, any such considerations would equally apply to a commercial or (as proposed) residential use of the Site, and should not in our opinion be a significant consideration as part of a Planning Proposal.

Further to the above, Australian and international research consistently shows a high percentage of walk to rail trips exceed the 800m standard; some examples of this research are provided below: -

- **Distances people walk for transport** (Matthew Burke and A.L. Brown) based on Brisbane walk trip data.



- **How far do we walk to the station?** (Davies) based on Melbourne walk trip data.



**Walkable Catchments Analysis at Auckland Train and Northern Busway Stations** (Auckland Council) based on Auckland walk trip data.

Train station	Walking distance for 50% (median) of respondents	Walking distance for 85% of respondents
Papatoetoe	1200m	2180m
New Lynn	1125m	2116m
Glen Innes	943m	1526m
Mt Albert	862m	1617m

- **Carbon Reductions and Co-benefits: Literature and practice review of Australian policies relating urban planning and public health** (Michael A P Taylor & Susan Thompson) based on Sydney, Melbourne and Brisbane walk trip data.

Statistic	Public transport mode								
	Train			Tram			Public bus		
	Access	Egress	Total	Access	Egress	Total	Access	Egress	Total
15th percentile (km)	0.30	0.30	0.78	0.14	0.13	0.38	0.22	0.22	0.58
25th percentile (km)	0.39	0.40	0.98	0.19	0.18	0.48	0.29	0.28	0.71
Median (km)	0.61	0.64	1.34	0.34	0.32	0.74	0.47	0.48	1.06
75th percentile (km)	0.94	0.96	1.87	0.56	0.56	1.11	0.81	0.80	1.52
85th percentile (km)	1.19	1.21	2.16	0.71	0.73	1.32	0.99	1.02	1.88
Mean (km)	0.74	0.75	1.49	0.43	0.42	0.84	0.61	0.60	1.22
Standard deviation (km)	0.50	0.51	0.73	0.35	0.32	0.48	0.48	0.48	0.70
Coefficient of variation	68%	68%	49%	81%	78%	57%	78%	79%	58%

All of this research indicates that the Site is well positioned to generate combined walk/public transport trips, which has the inherent benefit of reducing private vehicle trip generation to the local road network.

It is noted that the [Peer Review](#) provides additional discussion and support in regard to the walkability of the Site, providing the following conclusions: -

*The Site is within the Cherrybrook Study Area and within 800 metres of the new Cherrybrook station. If Council's position is accepted that the Site is suitably located in terms of pedestrian connections to the train station for pedestrians accessing their place of work, then it must also be accepted that it is suitably located for pedestrians accessing their place of residence. Or in simple terms, the Site is suitably located for pedestrian connections to the train station.*

*The length of a walking route to a train station has a greater impact on walkability than the gradient of that route due to topography. Accordingly, the benefits arising from the Site being within the target 800-metre walking catchment of Cherrybrook train station outweigh any perceived disadvantages associated with topography. Topographical factors should be viewed positively to justify expansion of the standard 800-metre walking catchment to maximise the transport benefits of the new rail infrastructure and to ensure its viability. The negative application of topographical factors as outlined by Council risks underutilisation of the NWRL, compromising its ability to achieve its target headways of 1 train every 4 minutes.*

## 2 Site Traffic Characteristics

The assessment of existing and potential trip generation further to commercial operations at the Site provided in sections below is entirely consistent with previous ARC assessments relating to earlier Planning Proposals for the Site.

### 2.1 2015 Site Trip Generation

Traffic surveys were conducted in November 2015 in order to determine the existing trip generation of the Site, and moreover a current peak hour trip rate (per 100m<sup>2</sup> GFA). To determine such, the AM and PM peak hour trip generation of the Site was essentially divided by the currently (2015) leased GFA; this provides the following trip rates: -

- AM Peak Hour            371 trips, or 1.4 trips per 100m<sup>2</sup> GFA
- PM Peak Hour            345 trips, or 1.3 trips per 100m<sup>2</sup> GFA

### 2.2 Capacity Commercial Trips

The current trip generation of the Site is significantly lower than generated in the past, or that which could realistically be generated ('tomorrow') were the Site to be leased in full for standard commercial operations. In this regard, it is noted that: -

- IBM, the major tenant, occupies a space significantly larger than (currently) required, resulting in a much lower staff occupancy per 100m<sup>2</sup> GFA than required.
- The current tenants (both IBM and Lend Lease) do not operate in accordance with standard office hours further to the provision of flexi-time and staff not working on-site at all times.

Critically, the total GFA of the Site could at any time be leased to tenants providing a standard office environment, i.e. standard office hours, and staff being on-site every day, as originally approved for the Site, and reflected in the amount of parking (some 1,613 parking spaces) provided at the Site.

In this regard, it is instructive to examine the RTA trip generation calculations used at the time when the Site was approved. The RTA Guide to Traffic Generating Developments (GTGD) until recently (2013) provided the following base calculations in determining commercial office peak hour trip rates: -

- A car travel mode of 62%
- A car occupancy of 1.19 persons per vehicle
- A resultant car driver mode 52%
- An average of 4.75 employees per 100m<sup>2</sup> GFA (or 21m<sup>2</sup> GFA per employee)
- 80% of employees departing in the PM peak hour

These calculations provide the GTGD PM peak hour trip generation rate of 2 trips per 100m<sup>2</sup> GFA (or an estimated Site trip generation of 680vph), a rate which has (again until recently) generally also been applied to the AM peak hour (though with reference to **Section 2.1** the existing Site trip generation is slightly higher in the AM peak hour, a finding consistent with the recent RMS Technical Direction 2013 04a – Guide to Traffic Generating Developments; Updated traffic surveys (GTGD Update)).

Critically though, the GTGD trip generation rates are 'accompanied' by a parking rate of 1 space per 40m<sup>2</sup> (which essentially accommodates the peak parking demand generated per the calculations above); application of this parking rate to the 34,000m<sup>2</sup> GFA provides a ('required') parking total of 850 parking spaces, compared to the 1,613 spaces actually provided on the Site. This in our opinion confirms past Site staff estimates, and the likelihood of a higher car driver percentage (based on relatively poor past public transport options, with 2011 *Journey to Work* data suggesting 84% of employees drive to the travel zone in which the Site lies). Overall, this strongly suggests that the Site has a significantly higher trip generation potential than that calculated by the application of the base GTGD rates.

As outlined above, at the time the Site was approved, the GTGD trip generation calculations provided an estimate of 80% of employees departing in the PM peak hour. If this is applied to the available parking of 1,600 spaces, this would suggest a PM peak hour trip generation of 1,280vph.

While acknowledging that the future public transport opportunities available to (proposed) residents would also be available to future commercial employees, there is little doubt in our opinion that the parking available at the Site could be fully utilised every day by a future commercial tenant, and indeed would likely be an important consideration for a future commercial tenant. Allowing for some broader flexibility in work hours: -

- An estimate of 70% of employees arriving/departing in a peak hour suggests a peak hour trip generation of 1,120vph
- An estimate of 60% of employees arriving/departing in a peak hour suggests a peak hour trip generation of 960vph

Based on an assessment of commercial parking provision, it is therefore estimated that the Site could generate a minimum of some 960 vph in a peak hour under capacity commercial operations. Again, the current zoning of the Site means that such a level of trip generation could occur by filling tenancies with commercial tenants undertaking standard commercial operations and fully utilising the existing 1,613 parking spaces provided on-site.

Notwithstanding the above, and with reference to the 2015 traffic surveys, even the (relatively) minor current commercial operations of the Site – with significantly lower employment (1,200 employees) and less than full occupancy of available floor space – generate some 376 trips in the AM peak and 344 trips in the PM peak. A simple factoring of these (relatively low) surveyed rates alone to account for the currently unused floor space (7,500m<sup>2</sup> GFA) provides a total Site trip generation estimate of 482 trips in the AM peak and 441 trips in the PM peak, a total that would be even higher if the common areas were returned to commercial space.

At present, some 1,200 people are employed at the Site; a simply factoring of 2015 employment numbers to the available Corridor Strategy employment estimates (to an estimated minimum of 2,000 jobs at the Site itself) provides a trip generation estimate of 626 trips in the AM peak and 573 trips in the PM peak.

## 2.3 Trip Distribution

### 2.3.1 Directional Distribution

Based on the traffic surveys, our on-site observations and a review of sub-regional trip paths, the following directional trip distribution has been determined: -

- Approximately 80% of trips to/from the north via Coonara Avenue, of which approximately: -
  - 65% to/from the east
  - 15% to/from the north
  - 20% to/from the west
- Approximately 20% of trips to/from the south via Coonara Avenue

There is no information to suggest that these distribution paths would be significantly different following the proposed rezoning.

### 2.3.2 Arrival & Departure Distribution

Based on the 2015 traffic surveys, the following arrival/departure trip distribution has been determined for the existing use of the Site: -

- In the AM Peak Hour: -
  - 93% of trips arrival
  - 7% of trips departure
- In the PM Peak Hour: -
  - 4% of trips arrival
  - 96% of trips departure

These arrival and departure patterns will change significantly following the rezoning (see **Section 3**).

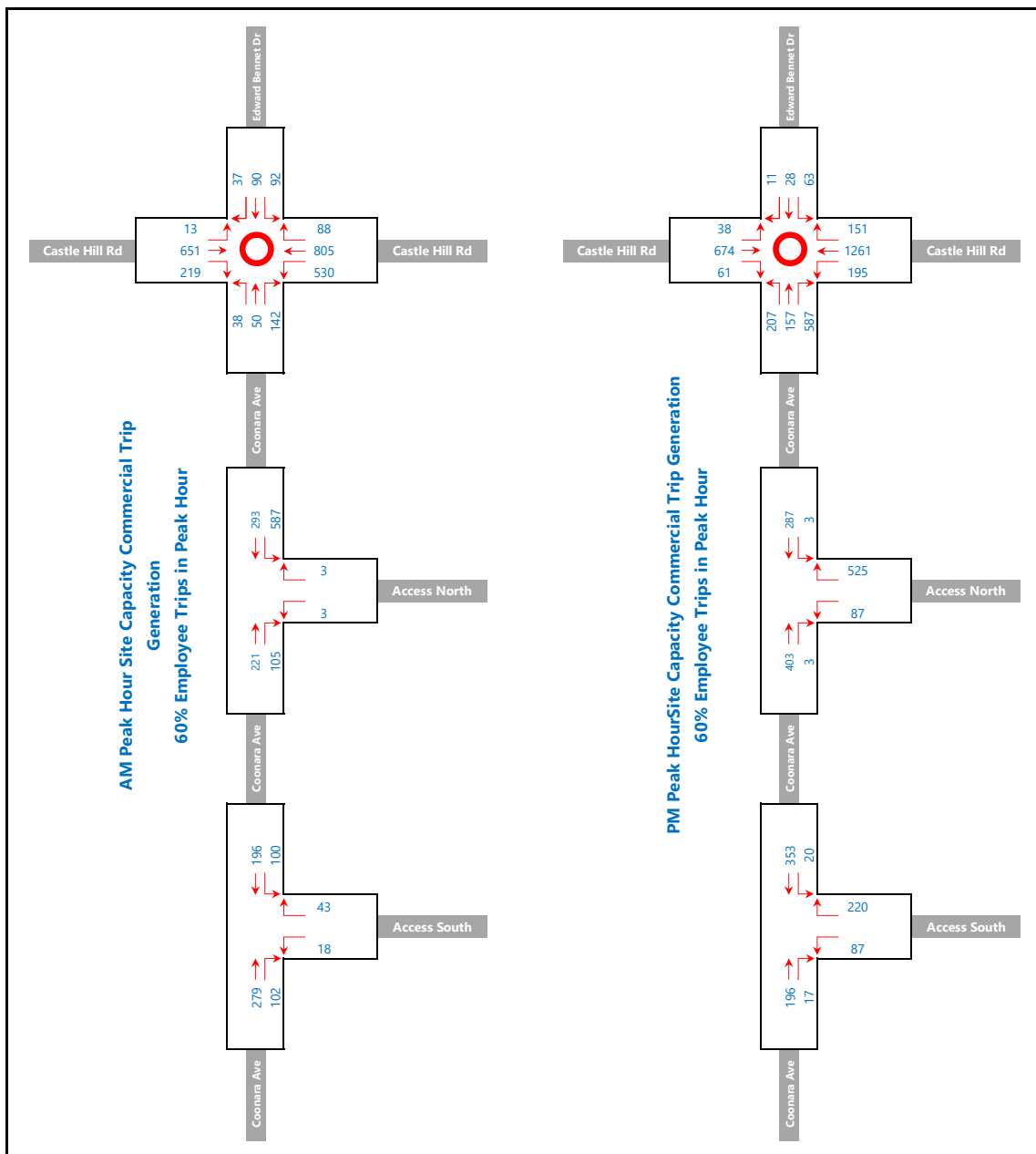


## 2.4 Capacity Site Assignment

As discussed, the Site is currently operating well below (traffic generating) capacity; however, for the purpose of this traffic assessment it is essential to consider the 'impacts' of the Site operating at capacity. As such, additional trips have been assigned to the Site access intersections, and to the key intersection of Castle Hill Road & Coonara Avenue & Edward Bennet Drive, based on the parking space Site trip generation estimate detailed in **Section 2.2** (60% car park capacity generated in a peak hour, or 960vph) and the trip distribution detailed in **Section 2.3**.

The resulting Site flows based on these capacity commercial operations are shown in **Figure 2.4**.

**Figure 2.4 Peak Hour Traffic Flows Site Capacity Commercial Operations**



## 2.5 Site Capacity Impacts

The impact of trips associated with the Site operating at commercial capacity (as shown in **Figure 2.4**) at the key intersection of Castle Hill Road & Coonara Avenue & Edward Bennet Drive have been assessed using SIDRA. This modelling indicates that the additional trips associated with commercial capacity operations would increase delays and reduce capacity at the intersection, particularly in the PM peak hour, such that it reports a level of service 'C' in the AM peak and a level of service 'F' in the PM peak.

In Coonara Avenue, these capacity commercial operations would generate approximately 730 vph two-way south of Castle Hill Road, and approximately 230 vph two-way south of the Site.

## 3 The Planning Proposal

### 3.1 Components

As stated, Mirvac proposes the rezoning of the Site to provide for a residential development. The Proposal supporting the rezoning provides for: -

- A total of 200 low density residential dwellings (detached, semi-detached, attached houses and townhouses)
- A total of 400 apartment dwellings, indicatively including: -
  - 20 studio apartments
  - 100 one-bedroom apartments
  - 220 two-bedroom apartments
  - 60 three-bedroom apartments
- A total of approximately 940 parking spaces (including 80 apartment visitor spaces), or some 670 spaces less than currently provided on-site.

### 3.2 Access

All vehicle access would continue to be provided by the existing Site access points. While the on-site access road network will be determined further to future detailed planning, preliminary concept plans indicate that access to all on-site areas would be available via both access points and the retention of the existing internal perimeter road system. This suggests that Access North may continue to provide for a higher percentage of arrival and departure trips given that most trips will continue to be to and from the north.

The detailed distribution of trips to the two access points (based on future internal road connectivity) would be determined further to more detailed future planning.

Further to our previous discussions with Council officers, it is Council's view that the design of the existing left turn entry lanes at both access points could be further augmented to appropriately distinguish these lanes as entry lanes, though it is noted that the existing design of these lanes has provided for the Site since opening, and that the Proposal would significantly reduce traffic movements to these lanes. Notwithstanding, the design of these lanes could be further investigated as part of future detailed design stages, and should not in our opinion have specific bearing on the broader Planning Proposal submission.

### 3.3 Public Transport

One of the key focuses of the Proposal is the accessibility of the Site to Cherrybrook Station and sub-regional bus services in Castle Hill Road. It is the opinion of ARC that the high frequency of services available to future residents will ensure a significant uptake of public transport usage.

In addition, there is significant potential to extend local bus services to link the Site with Cherrybrook Station, either utilising the future network outlined in the [Cherrybrook Structure Plan](#), i.e. with a potential new link west from Coonara Avenue opposite the Site; and/or utilising the bus accessible internal Site road network. At the very least, bus services linking the Site with Cherrybrook Station along Coonara Avenue and Castle Hill Road, utilising the existing bus stops immediately adjacent to the Site, would provide an excellent level of additional accessibility and connectivity.

As also previously discussed, Council is currently finalising proposals for new bus services and bus priority lanes between Castle Hill and Parramatta via Crane Road, Castlewood Drive and a new bus only bridge to Highs Road (and then south via Taylor Street, Aitkens Road and Oakes Road towards Parramatta). The potential exists for local routes (via Coonara Avenue) as described above to also connect to this corridor (west to Castle Hill and/or south to Parramatta).

### 3.4 Pedestrian & Cycle Links

The future internal road network would necessarily provide an excellent level of pedestrian/cycle accessibility to Coonara Avenue. As discussed, at Coonara Avenue an existing path provides access to Cherrybrook Station via the Castle Hill Road & Edward Bennet Drive intersection, recently augmented by the new pedestrian crossing of the Coonara Avenue approach and indeed by the path along the western side of Coonara Avenue past the Site, further improving accessibility for walk trips to/from Cherrybrook Station.

Additionally, and as discussed in **Section 1.6**, the [Cherrybrook Structure Plan](#) also identifies a future connection directly opposite the Site linking to the west and then north to Cherrybrook Station via Staley Court (or potentially via Glenhope Road). Again, these future paths would even further enhance the connectivity of the Site to Cherrybrook Station.

### 3.5 Trip Generation

The assessment of future trip generation further to residential development of the Site provided in sections below is entirely consistent with our previous assessment. As stated previously, this assessment methodology has been previously discussed and agreed with Council officers.

### 3.5.1 Apartment Component

#### 3.5.1.1 RMS Trip Rates

The GTGD Update provides surveys of high density residential sites across the Sydney metropolitan area (and Newcastle and Wollongong). Almost all of the GTGD Update survey sites lie within close proximity of rail, and most are also located near regional or sub-regional centres (i.e. in immediate proximity of employment, retail and other services). Summary rates provided in the GTGD Update are shown below.

**Table 3.5.1.1 RMS GTGD Update High Density Residential Trip Rates**

Weekday Rates	Sydney Average	Sydney Range	Regional Average	Regional Range
AM peak (1 hour) vehicle trips per unit	0.19	0.07-0.32	0.53	0.39-0.67
AM peak (1 hour) vehicle trips per car space	0.15	0.09-0.29	0.35	0.32-0.37
AM peak (1 hour) vehicle trips per bedroom	0.09	0.03-0.13	0.21	0.20-0.22
PM peak (1 hour) vehicle trips per unit	0.15	0.06-0.41	0.32	0.22-0.42
PM peak (1hour) vehicle trips per car space	0.12	0.05-0.28	0.26	0.11-0.40
PM peak (1 hour) vehicle trips per bedroom	0.07	0.03-0.17	0.15	0.07-0.22
Daily vehicle trips per unit	1.52	0.77-3.14	4.58	4.37-4.78
Daily vehicle trips per car space	1.34	0.56-2.16	3.22	2.26-4.18
Daily vehicle trips per bedroom	0.72	0.35-1.29	1.93	1.59-2.26

As discussed and agreed with Council traffic officers, the application of the RMS base trip generation rates directly to the apartment component of the Proposal would understate potential trip generation. Specifically, it is not appropriate – as part of a sensitivity assessment – to assign rates that are primarily based on sites within key metropolitan centres with immediate proximity not only to public transport, but also to employment and other daily services. Notwithstanding, it is also the case that the proposed apartments will have a significantly lower occupancy than standard dwellings, which in and of itself reduces trip generation potential.

Based on a more detailed analysis of the GTGD Update data, and with reference to the previous GTGD, it is our opinion that an appropriate rate of trip generation would be similar to that previously assigned to high density residential development in sub-regional centres (as detailed in Section 3 of the GTGD) – a rate of 0.29 trips per dwelling, or a rate some 35% higher than the summary GTGD Update AM peak hour rate. This trip generation rate has then been modified further, providing for the GTGD Update identification of trip rate differences based on parking provision (see also **Section 3.9** below). Accordingly, ARC provides the following trip rates for the assessment: -

- 0.30 trips per apartment in the AM and PM peak hour
- 0.25 trips per parking space (including apartment resident and visitor spaces) in the AM and PM peak hour

It is again noted that these trip generation rates are identical to those used in previous assessments.

### 3.5.1.2 Total Apartment Trip Generation by Dwelling Trip Rate

Based on the trip rates per apartment detailed above, the trip generation of the apartment component of the Proposal would be 120 vph in both the AM and PM peak.

### 3.5.1.3 Total Apartment Trip Generation by Parking Provision Trip Rate

With reference to **Section 3.9** below, it is proposed that parking for the Proposal be provided further to consideration of the parking rates outlined in the Apartment Design Guide (ADG) and the (draft) Hills LEP Castle Hill North amendments, and provides: -

- 1 space per studio, one-bedroom and two-bedroom apartment
- 2 spaces per three-bedroom apartment
- 1 space per 5 apartments for apartment visitors

Based on these parking rates, the apartment component of the Proposal would require a total of some 540 parking spaces. Based on the trip rate per parking space detailed above, the trip generation of the apartment component of the Proposal would be 135 vph in both the AM and PM peak.

### 3.5.1.4 Council High Density Trip Generation Rates

As discussed and agreed with Council officers, the trip rates assessed in sections above specifically acknowledge the different characteristics of the Site when compared to the primary sites surveyed by the RMS (per the GTGD Update), including the immediacy of employment and services, and availability of/access to public transport services.

Notwithstanding, and as a point of comparison, Council surveys of high density residential development are reported in the 2006 (Council) Traffic Impact Report: Balmoral Road Release Area (BRRA Report). These surveyed trip rates were generally 50% higher than the GTGD trip rates at the time, specifically: -

- 0.35 peak hour trips per one or two-bedroom dwelling
- 0.5 peak hour trips per three-bedroom/four-bedroom dwelling

Based on these Council trip rates, the trip generation of the apartment component of the Proposal would be 149 vph in both the AM and PM peak periods. Importantly though, the BRRA Report also specifically provides the following caveat in regard to these Council trip rates: -

*The Baulkham Hills Council traffic generation rates are reflective of the Shire where access to public transport is limited. Using the [significantly lower] RTA rates would more accurately reflect the greater Sydney Traffic generations, where there is greater access to public transport. This would be relevant to consider with the provision of the proposed Transitways and, ultimately, the North-West Rail link to this area.*

*Using the RTA rates is a conservative estimate of traffic generating potential with some improvement for public transport mode share. Further reduction in traffic generation could be achieved with increased public transport mode share. If higher public transport mode share is achieved there is an obvious lowering of the vehicular traffic generation, particularly in the critical AM peak travelling period.*

It is certainly our opinion that the future accessibility to Cherrybrook Station (and indeed sub-regional bus services in Castle Hill Road) will unequivocally lead to an increase in public transport mode share.

## 3.5.2 Housing Component

### 3.5.2.1 RMS Trip Rates

The GTGD Update provides the following summary trip rates for low density residential dwellings: -

- 0.95 trips per dwelling in the AM peak hour
- 0.99 trips per dwelling in the PM peak hour

As with high density residential trip rates, the GTGD Update low density summary rates are based on survey sites across metropolitan Sydney (and regional centres), and it is noted that a survey of Beaumont Hills (within The Hills LGA) is included, which reports trip rates of 1.2 trips per dwelling in the AM peak hour, and 1.1 trips per dwelling in the PM peak hour.

However, unlike the discussion in regard to the GTGD Update high density summary trip rates, the Site will provide significantly higher accessibility to public transport and sub-regional services than are available to residents in Beaumont Hills (and many of the other low density areas surveyed to provide the GTGD Update summary rates). This is evident with a review of the GTGD Update survey data for the Westleigh survey site (noting that Westleigh is expected to provide very similar accessibility characteristics as the Site) where the AM and PM peak hour trip rate per low density dwelling is 0.6 trips per dwelling.

Overall, there is evidence that the low density summary trip rates provided in the GTGD Update may therefore overstate the trip generation potential of the proposed low density residential dwellings at the Site, but these summary rates have been adopted for the assessment.

### 3.5.2.2 Total Housing Trip Generation

Based on the GTGD Update summary trip rates per dwelling detailed above, the trip generation of the housing component of the Proposal would be 190 vph in the AM peak, and 198 vph in the PM peak.

### 3.5.3 Total Proposal Trip Generation

With reference to sections above, and applying the higher Council trip generation rates to the apartment component of the Proposal and the GTGD Update summary trip rates to the housing component of the Proposal, the worst case total trip generation of the Site is estimated at: -

- 339 vph in the AM peak
- 347 vph in the PM peak

Notwithstanding the use of these trip totals for the assessment, it is the opinion of ARC that the total trip generation of the Proposal would be nearer 300 vph in both peak periods further to consideration of trip reductions given the significantly improved public transport accessibility (from that considered in the Council high density trip rates); and the likelihood of the housing component of the Site displaying trip characteristics more similar to those of the GTGD Update Westleigh survey site.

## 3.6 Trip Distribution

While no significant changes to directional distribution (from that identified in **Section 2.3**) are expected following the rezoning, the arrival and departure distribution will change (from that identified in **Section 2.3**), with the majority of AM peak hour trips being departure trips (as opposed to existing arrival trips) and vice versa in the PM peak. The following arrival/departure distribution profile has been assigned to future Site residential trips: -

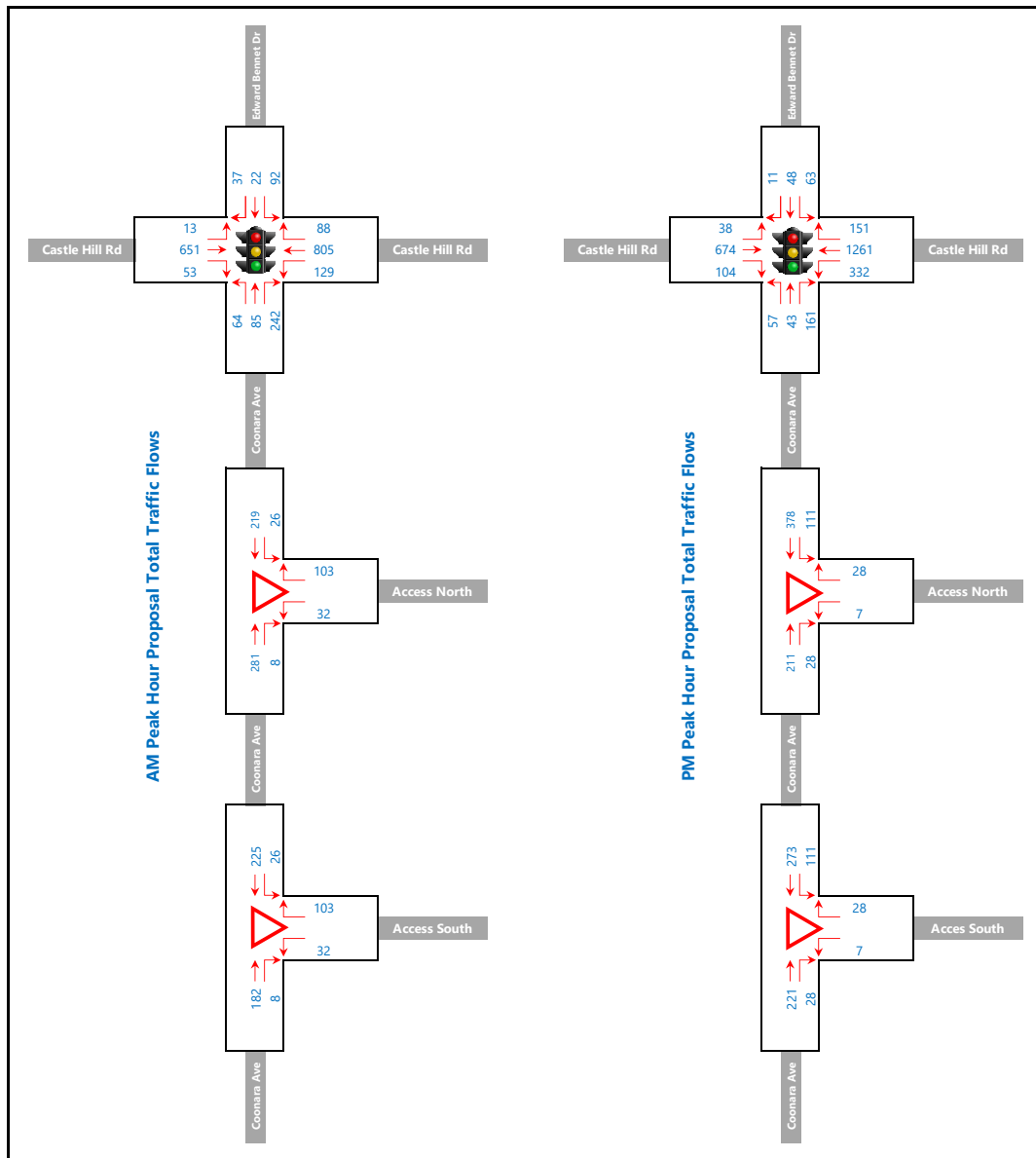
- In the AM Peak Hour: -
  - 20% of trips arrival
  - 80% of trips departure
- In the PM Peak Hour: -
  - 80% of trips arrival
  - 20% of trips departure

## 3.7 Future Trip Assignment

With reference to sections above, the (worst-case) forecast trip generation of the Proposal as summarised in **Section 3.5.3** has been assigned to the local road network, entirely replacing commercial trips as assigned in **Section 2.4**. The resulting flows at the key intersections are shown in **Figure 3.7** below.



**Figure 3.7 Proposal Total Traffic Flows**



### 3.8 Traffic Impacts

#### 3.8.1 Site Trip Generation Comparison

Based on the trip generation potential of the Site based on various commercial capacity scenarios, and the trip generation of the Proposal with reference to either the ARC/GTGD Update trip rates or the Council trip rates for the apartment component of the Proposal, it is immediately apparent that the trip generation of the Proposal would be significantly less than commercial use of the Site.

With reference to the worst-case total trip generation estimate for the Proposal provided in **Section 3.5.3** (based on the Council trip rates for the apartment component of the Proposal, and the GTGD Update summary rates for the low density component of the Proposal) and the various commercial operations trip estimates provided in **Section 2.2, Table 3.8.1** provides a comparison of trip generation for the different Site scenarios: -

**Table 3.8.1 Proposal Trips v Commercial Trips**

Commercial Trip Generation Factor	Traffic Generation Scenario	AM Trip Rate	AM Trips	PM Trip Rate	PM Trips
34000	m <sup>2</sup> GFA 2016 Full Commercial Occupancy	1.42	482	1.30	441
1600	Site Parking Spaces Peak Trips	60%	960	60%	960
2000	Corridor Strategy Employee Forecast	0.31	626	0.29	573

Proposal Trip Generation Factor	Traffic Generation Scenario	AM Trip Rate	AM Trips	PM Trip Rate	PM Trips
400	Apartments by Size	0.35/0.5	149	0.35/0.5	149
200	Houses	0.95	190	0.99	198
<b>600</b>	<b>Total Dwellings</b>		<b>339</b>		<b>347</b>

Proposal Trip % of Commercial Trips	AM Trips	PM Trips
Proposal trips % of 2016 Full Commercial Occupancy Trips	70%	79%
Proposal trips % of Site Parking Spaces Peak Trips	35%	36%
Proposal trips % of Precinct Plan Employees Forecast Trips	54%	61%

In summary, there is no question that the Proposal would generate significantly fewer trips than would be generated by the Site under commercial operations. This is a conclusion that was (without prejudice) agreed with Council officers in our meeting of 13<sup>th</sup> September 2016 (discussing the October 2016 Planning Proposal) even when considering the higher trip generation of the previous July 2016 Planning Proposal which provided for some 1,119 dwellings and 1,500 parking spaces, or 519 dwellings and 560 parking spaces more than provided for in the current Proposal.

This in turn will result in significantly fewer trips being generated to Coonara Avenue and the local road network. The Proposal would generate approximately 260 to 280 vph two-way south of Castle Hill Road (compared with 730 vph under capacity commercial operations) and some 70 to 80 vph two-way south of the Site (compared with 230 vph under capacity commercial operations) during the peak periods. As such, there would be significantly fewer trips being generated to the key intersection of Castle Hill Road & Coonara Avenue & Edward Bennet Drive (see also **Section 3.8.2** below) and to the southern route than would be generated further to capacity commercial operations at the Site.

With regard to the southern route, it is estimated that the Proposal would generate approximately 40 additional southbound trips per hour to this route in the AM peak than would be generated by capacity commercial operations, but at the same time generate approximately 190 fewer northbound trips to the route. Similarly, in the PM peak the Proposal would generate approximately 35 additional northbound trips per hour to this route than would be generated by capacity commercial operations, but at the same time generate approximately 160 fewer southbound trips to the route.

As agreed with Council, a detailed review of the southern route is outside of the scope of this Planning Proposal assessment, but with reference to these overall reductions during both peak periods, and further to Council's bus priority proposals for the southern route (connecting directly between Castle Hill and Parramatta), the Proposal is not expected to have any significant impact on the operation of the southern route.

### 3.8.2 Intersection Operations

As discussed above, the residential trips generated by the Proposal would have a different distribution pattern to those generated by commercial operations at the Site, specifically in regard to the arrival and departure distribution at the intersection of Castle Hill Road & Coonara Avenue & Edward Bennet Drive. As such, it is of course acknowledged that the Proposal would generate more outbound trips than under capacity commercial operations in the AM peak, but at the same time it would generate significantly fewer inbound trips (in the AM peak). Similarly, in the PM peak the Proposal would generate more inbound trips than under capacity commercial operations, but significantly fewer outbound trips.

Notwithstanding these changes, the Proposal would provide for significant reductions in overall trip generation to the intersection in both peak periods, and while (for example) there is a moderate increase in the departure demand from Coonara Avenue in the AM peak further to the Proposal, that increase is balanced by significantly reduced arrival demands from Castle Hill Road and Edward Bennet Drive. As such, SIDRA testing of the existing intersection design and phasing indicates that the Proposal would result in a similar level of service to capacity commercial operations (as detailed in **Section 2.5**) in the AM peak (level of service 'C') but with a significantly improved level of service in the PM peak (level of service 'C' compared to level of service 'F') reflecting the significant reduced outbound demand generated by commercial operations. Moreover, this level of service 'C' in the PM peak compares to the existing level of service 'E' currently reported at the intersection.

Further to the benefits of the Proposal reducing overall traffic flows at the intersection, sensitivity testing of the proposed future upgrade of the intersection (by others) indicates that there would be additional improvements in operations (either compared to existing operations or to capacity commercial operations) under the Proposal, particularly in the AM peak hour given the proposed additional approach capacity in Coonara Avenue providing for residential departures.

As discussed and agreed with Council officers, it is not appropriate to provide a detailed forecast assessment of the future intersection flows while Precinct wide assessments are yet to be completed. Notwithstanding, all available information indicates that the intersection of Castle Hill Road & Coonara Avenue & Edward Bennet Drive would perform at a high level of service further to the Proposal than would be the case if the Site was accommodating commercial operations.

With regard to the Site access intersections, SIDRA modelling indicates that these intersections will continue to operate at a good level of service in both peaks, even if a higher percentage of trips are generated to Access North than suggested in **Figure 3.7**; indeed, all trips could be generated to a single access intersection (noting that this is not proposed) while still retaining a good level of service.

## 3.9 Parking

### 3.9.1 Parking Requirements

#### 3.9.1.1 Apartment Component

The parking requirements for the apartment component of the Proposal can be determined with reference to the ADG, which provides the following: -

*For development in the following locations:*

- *on sites that are within 800 metres of a railway station or light rail stop in the Sydney Metropolitan Area; or*
- *on land zoned, and sites within 400 metres of land zoned, B3 Commercial Core, B4 Mixed Use or equivalent in a nominated regional centre*

*the minimum car parking requirement for residents and visitors is set out in the Guide to Traffic Generating Developments, or the car parking requirement prescribed by the relevant council, whichever is less.*

Reference in turn to the GTGD (for sub-regional centres) provides the following rates: -

- 0.6 spaces per one-bedroom apartment
- 0.9 spaces per two-bedroom apartment
- 1.4 spaces per three-bedroom apartment
- 1 space per 5 units for (apartment) visitor parking

Based on these parking rates, the apartment component of the Site would require a minimum of 434 parking spaces.

It is noted that these rates are similar to, though slightly less than, the minimum parking requirements when calculated with reference to the recently proposed amendment to the (draft) Hills LEP, which require 1 space per unit (all sizes) and an additional 1 space per 4 units, or a total of some 500 parking spaces when applied to the apartment component of the Proposal. These rates in turn are similar to those provided for high density development in the North Kellyville DCP (acknowledging that this is a DCP prepared by the Department of Planning & Environment, not Council) even though high density sites within the North Kellyville Precinct are not provided with equivalent access to rail as provided at the Site.

#### 3.9.1.2 Housing Component

The Hills DCP requires the provision of 2 parking spaces per dwelling house.

## 3.9.2 Proposed Parking

### 3.9.2.1 Apartment Component

With reference to the ADG minimum requirements outlined in **Section 3.9.1.1** above, the proposed amendments to the (draft) Hills LEP, and moreover to provide a sustainable level of car parking that responds to current market conditions without unduly increasing trip generation or demand for off-site parking, the following parking rates are proposed for the apartment component of the Proposal: -

- 1 space per studio apartment
- 1 space per one-bedroom apartment
- 1 space per two-bedroom apartment
- 2 spaces per three-bedroom apartment
- 1 space per 5 units for apartment visitor parking

Based on these parking rates, the apartment component of the Proposal will provide a total of 540 parking spaces, some 106 spaces more than the minimum provided for under the ADG.

### 3.9.2.2 Low Density

With reference to the Hills DCP, a total of 400 parking spaces will be provided for the housing component of the Proposal, or 2 spaces per dwelling.

## 3.9.3 Proposal Parking Total

With reference to sections above, a total of 940 parking spaces would be provided for the Proposal, some 670 spaces fewer than currently provided on the Site.

It is anticipated that these (residential and residential visitor) spaces would be provided as part of the Proposal utilising garage spaces and driveways (for the low density dwellings), and new parking levels designed within residential apartment buildings. It is noted that parking (and specifically visitor parking) may also be provided for on-street within the Site, and/or in the existing multi-storey car park in the northern part of the Site.

The detailed design of parking areas would be undertaken as part of a future design process (as part of a future Site specific Development Application) and necessarily provide compliance with Australian Standards.

### 3 Conclusions

Further to a detailed assessment, ARC has determined that the Proposal would generate significantly fewer trips to the local road network than would be generated by commercial operations at the Site, and that as such all information supports a conclusion that the Proposal would have a reduced impact on the local traffic environment when compared to commercial operations at the Site.

Specifically, ARC has determined that: -

- The Site is very well located for future residents to utilise Cherrybrook Station (currently under construction) with pedestrian access further improved by the recently installed signalised crossing of the Coonara Avenue approach to Castle Hill Road, and provision of a new path along the western side of Coonara Avenue past the Site. Further, the Cherrybrook Structure Plan indicates new future links immediately west of the Site in turn linking to Cherrybrook Station, links which would likely provide additional efficient pedestrian/cycles routes between the Site and Cherrybrook Station. The walkability of the Site – specifically to the future Cherrybrook Station – is strongly supported by the Peer Review.
- There are excellent opportunities to supplement local bus routes to provide more frequent services between the Site and Cherrybrook Station, either via the links indicated in the Cherrybrook Structure Plan; via Coonara Avenue; or indeed through the Site itself, a more than viable opportunity given the future residential population of the Site. These routes also have the potential to utilise the future bus priority corridor between Castle Hill and Parramatta, plans for which are currently being finalised by Council.
- The past trip generation of the Site – and most significantly the potential trip generation of the Site that could be generated 'tomorrow' based on the existing floorspace, the existing 1,613 on-site parking spaces, and the existing commercial zoning – is significantly higher than currently being generated. It is estimated that capacity commercial operations could generate some 1,000vph to the commuter peak periods.
- The trip generation of the Proposal would be significant lower during the peak periods than capacity commercial operations, estimated at approximately 340 - 350 vph in the commuter peak periods when applying Council's (maximum) trip generation rates to the apartment component of the Proposal; and at approximately 330 vph in the commuter peak periods when applying the (ARC factored) GTGD Update trip rates per parking space to the apartment component of the Proposal. Additional consideration of the similarly located Westleigh low density survey site data in the GTGD Update would suggest total Site flows further to the Proposal of approximately 300 vph in both peaks.
- Notwithstanding, and as agreed with Council officers, the total trip generation determined with regard to any of these rates is significantly less than would be generated under capacity commercial operations at the Site; and significantly less than would be generated based on the Corridor Strategy employment estimates for the Site.

- The Proposal would generate some 450 - 470 fewer trips in the peak hours to Coonara Avenue north of the Site, and some 150 - 160 fewer trips in the peak hours to Coonara Avenue south of the Site, when compared to capacity commercial operations.
- While it is acknowledged that future flows at the intersection of Castle Hill Road & Coonara Avenue & Edward Bennet Drive are yet to be modelled in detail as part of planning for the broader Cherrybrook Precinct, sensitivity modelling using SIDRA indicates that irrespective of the potential future upgrade of the intersection, the significantly reduced trip generation of the Site further to the Proposal – even accounting for the change in distribution - would result in similar operations at the intersection in the AM peak (compared to existing or capacity commercial operations); and significantly improved operations in the PM peak (compared to existing or capacity commercial operations). The currently proposed upgrades at the intersection to be completed by others as part of the broader Cherrybrook Precinct infrastructure works would further improve intersection operations under the Proposal, particularly in the AM peak given the proposed additional Coonara Avenue departure infrastructure.
- The Proposal would generate significantly fewer trips to the southern route in both peak periods. While it has been agreed with Council that a detailed review of the southern route is outside of the scope of this Planning Proposal assessment, reference to these overall reductions compared to capacity commercial operations, and to Council's bus priority proposals for the southern route (connecting directly between Castle Hill and Parramatta), indicates that the Proposal would have little if any significant impact on the operation of the southern route.
- The Site access intersections would operate at a good level of service as a function of the very moderate Site trip generation and Coonara Avenue through traffic flows. This would be the case even if all trips were generated to a single Site access point, though the proposed internal road network is expected to provide for a balance of trips between the two (existing) access points.
- Parking is proposed at an appropriately sustainable level which would remove the potential for off-site parking demand while simultaneously reducing the potential for additional Site trip generation. The Proposal would provide some 670 less parking spaces than currently provided on-site.

**It is the conclusion of ARC that the Proposal is therefore supportable in regard to traffic and transport considerations, a conclusion supported by the Peer Review.**